



Honda™ 35cc LITE Owner's Manual



⚠ ATTENTION: PRIOR TO FIRST USE ⚠

It is recommended that everyone who uses this product should read this StrikeMaster Owner's Manual.

You MUST add crankcase oil to your new Auger prior to your first use!
We recommend using the bottle of StrikeMaster API rated SM (as a minimum) OW-20 4-Cycle Synthetic Engine Oil included. For longer life of the engine, continue to use the required API rated SM (as a minimum) OW-20 4-Cycle Synthetic Engine Oil.

For best performance, idle engine for 1-2 minutes before you start drilling.

STRIKEMASTER® Ice Augers

Ice Fishing has become one of the fastest growing and most popular winter sports, allowing the ardent angler the opportunity to enjoy their favorite outdoor activity year round.

When you purchase a StrikeMaster® power ice auger, you selected a product that has gained a reputation as the quality leader since 1946. There is no doubt that this year's model is the finest ever produced by StrikeMaster.

Your new StrikeMaster ice auger has all of the most wanted features in a power ice auger, to assure many years of enjoyable ice fishing. Some of these features such as workmanship, engineering excellence, and dependability have long been standards at StrikeMaster. Your new power ice auger boasts many new features while retaining the best features developed in previous years to enhance your ice fishing experience and add to your satisfaction in selecting StrikeMaster.

We know that you are anxious to go fishing and use your new power ice auger, but before you go fishing, it is important and to your advantage to spend a few minutes getting acquainted with your new StrikeMaster power ice auger. There is no better way to acquaint yourself with the product than to read the Owner's Manual and operating instructions. A few minutes spent studying this manual before your first ice fishing outing will be time well spent.

Record the engine serial number, engine type and date purchased in the space below. Also, please return the enclosed WARRANTY CARD or submit your information at www.strikemaster.com to validate your limited warranty.

Model: Honda 35cc Lite

Engine Serial Number _____ - _____ Engine Type _____

Date Purchased ____ / ____ / ____

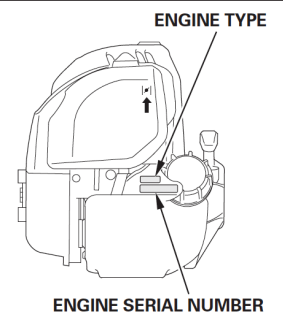

! ATTENTION !

! THIS SYMBOL POINTS OUT IMPORTANT SAFETY INSTRUCTIONS WHICH IF NOT FOLLOWED COULD ENDANGER THE PERSONAL SAFETY AND/OR PROPERTY OF YOURSELF AND OTHERS. READ AND FOLLOW ALL INSTRUCTIONS IN THIS MANUAL AND ANY PROVIDED WITH OR ON THE EQUIPMENT ON WHICH THIS ENGINE IS USED BEFORE ATTEMPTING TO OPERATE YOUR STRIKEMASTER POWER ICE AUGER.

! IMPORTANT NOTICE !

DO NOT REMOVE THE GREEN INTAKE GASKET. See photo for location on engine. Not only will removing the green intake gasket void the warranty, if removed the engine will not work properly and could cause damage.

If removed, replacement of the green intake gasket is **NOT** covered under Honda or StrikeMaster limited warranties.

For service contact your local authorized Honda Engine Dealer or visit www.strikemaster.com for more information by clicking the "Find Service Centers" button to search service centers by zip code. For more information from Honda click the "Visit Honda" button.



⚠ IMPORTANT SAFEGUARDS ⚠

It is recommended that everyone who uses this product should read this StrikeMaster Owner's Manual before operating.

1. **DO NOT** use this product for any purpose other than cutting ice fishing holes. Ice augers are precision cutting tools built for the ice fisherman, and must be properly maintained and handled with caution during both cutting and transporting. When not in use, always store with blade guard attached.
2. **DO NOT** use attachments other than those available from the manufacturer.
3. **DO NOT** alter this product in any manner; doing so is dangerous and voids all warranties.
4. **DO NOT** allow children or adults weighing under 100 lbs. to operate this equipment.
5. **DO NOT** operate under the influence of drugs or alcohol.
6. **DO NOT** allow your body, loose clothing, drawstrings, scarves, hats or other materials to come in contact with the Powerhead, Starter Assembly or Auger (Drill) unit at any time.
7. **DO NOT** operate if, upon pulling the starter rope or after drilling holes, the auger (drill) unit rotates or if the rope pulls hard. Have the unit checked by a qualified mechanic.
8. **DO NOT** allow the engine to run or operate while moving or transporting to another location.
9. **DO NOT** continue to use this product in the event of mechanical or electrical failure.
10. This product produces considerable cutting force that is felt by the operator. Make sure your feet are firmly planted and that the handles are held firmly while operating this product.
11. Always check the operation of the throttle system to ensure the carburetor control is completely returning to the idle position when the throttle lever is released.
12. **CHECK** cutting blade screws and collar bolt before and after each use to make sure they are tight.
13. During operation, the auger unit could possibly stop. Be prepared at all times to release the throttle lever.
14. The cutting blades on the ice auger are razor sharp. Use extreme care when handling.
15. After use, the auger blades should be wiped dry and oiled to extend blade life.

⚠ CHECKING/ADDING GASOLINE & OIL ⚠

Your new 4-stroke auger engine does **NOT** come filled with oil or gasoline. You will need to add StrikeMaster API rated SM (as a minimum) OW-20 4-Cycle Synthetic Engine Oil to the crankcase reservoir and unleaded gasoline to the fuel tank prior to your first use. Using a gas/oil mixture will damage the motor.

Honda Motor Co. requires you use only API rated SM (as a minimum) OW-20 4-Cycle Synthetic Engine Oil with the Honda 35cc Lite auger engine.

See included Honda Owner's Manual for step by step instructions or go to: <http://engines.honda.com/pdf/manuals/00X37Z6J6100.pdf> to download a digital copy.

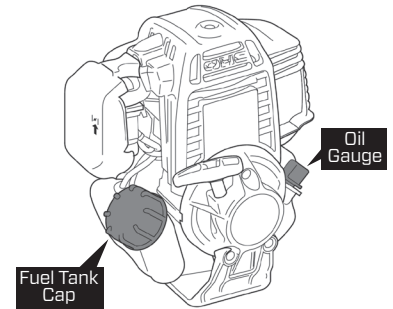

Suggested position to check oil

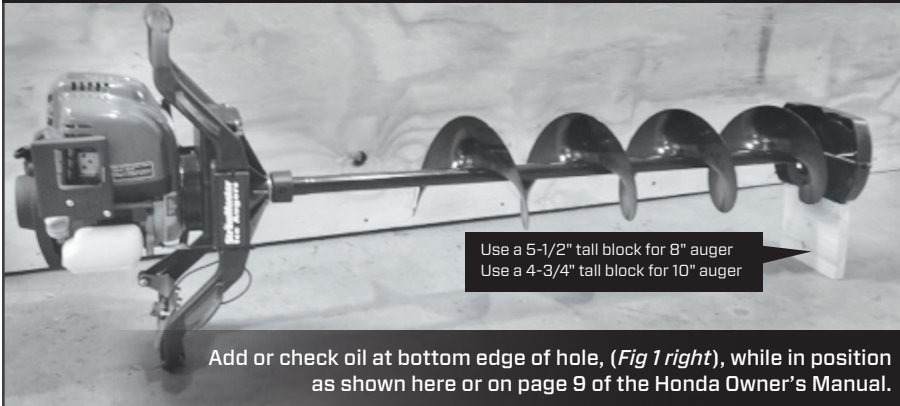
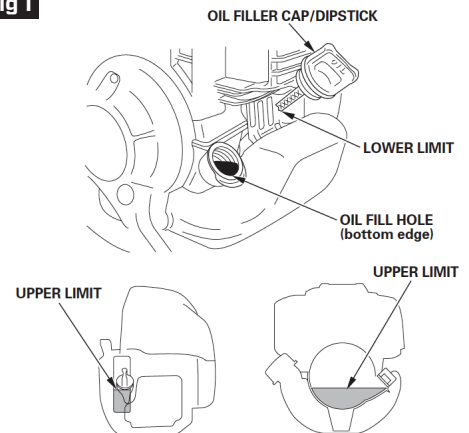

Fig 1



The Honda (GX35 engine) is a non-application specific manual. Any further technical engine guidelines that are not covered in the StrikeMaster Owner's Manual, refer to the Honda Owner's Manual. **Unit shipment also includes correct amount of StrikeMaster API rated SM (as a minimum) OW-20 4-cycle synthetic engine oil for initial fill (3.4 oz.).** Honda GX35 engine crankcase capacity has a maximum oil capacity of 3.4 oz. **DO NOT OVERFILL.**

Also, running the engine with a low oil level can cause engine damage. This type of damage is not covered by the Distributor's Limited Warranty.

See Honda Owner's Manual for other information such as air cleaner, spark plug, and fuel filter.

⚠ INITIAL ASSEMBLY ⚠

- 1** Carefully remove blade guard and make sure blade bolts are tight.

(8mm closed end wrench)



- 2** Remove metric allen wrench taped to the neck of auger and unscrew the collar bolt from auger.

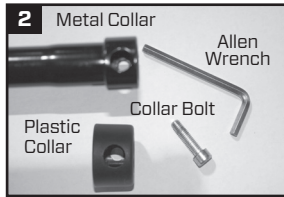

- 2a** The large and small holes from each component must line up before installing the collar bolt.



Push down and twist to line up holes.

- 3** Recommended to grease inside collar and transmission output shaft on the powerhead. Insert auger onto output shaft and install collar bolt.

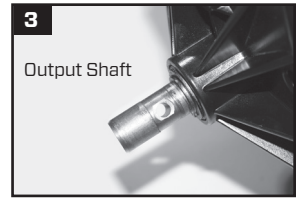

- 3a** Collar bolt inserts into the large hole, passes through the output shaft and threads into the small hole of the metal collar. Make sure bolt is tight. Check and tighten often.

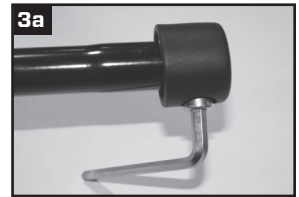

- 4** After assembly is complete, you can conveniently store your allen wrench on the underside of the throttle pedal.

- ⚠** It is recommended that the collar bolt be checked and torqued firmly before and after every use.



⚠ OPERATION ⚠

1. To start, rotate ON/OFF switch to the **ON** position. Slide choke lever to the **START** position. Press primer bulb 5-10 times or until fuel is visible in return line. Pull recoil short and quick. As soon as engine fires, slide choke lever to run position and allow engine to idle for 1-2 minutes before drilling.
2. This product produces considerable cutting force that is felt by the operator. Make sure your feet are firmly planted and that the handles are held firmly while operating this product, centrifugal clutch will engage and the auger will begin to rotate.
3. During the operation of cutting, the auger could possibly stop if it comes in contact with a foreign object or if it binds in the hole. Be prepared at all times to release the throttle lever to avoid rotation of the handle assembly.
4. Hold the unit in a vertical position with your right hand pushing downward to open throttle and your left hand firmly holding the opposite handle.
5. Use caution when removing or replacing blade guard. The cutting blades on the ice augers are razor sharp. Use extreme care when handling.
6. Always keep the blade guard on auger, except when in use.
7. The use of this auger by children or adult under 100lbs. is not recommended.

⚠ STOP ENGINE ⚠

After completing the cutting of an ice fishing hole, **STOP** the engine by allowing the engine to return to idle and moving the ignition switch to the OFF position. If the engine fails to stop, move the choke lever to the FULL CHOKE position to kill the engine. Always check the throttle system to ensure the carburetor throttle lever is returning to the idle position. If the ignition switch should fail, **DO NOT** operate until the ignition switch has been repaired by a qualified mechanic.

⚠ STORAGE ⚠

The following are storage recommendations only. Because of today's fuels StrikeMaster cannot guarantee results.

ENGINE OIL

- Change crankcase oil before the start or at the end of each season or 50hrs of use with fresh StrikeMaster API SM (as a minimum) 0W-20 4-Cycle Synthetic Engine Oil.

CLEAN AND STORE EACH SEASON

- At the end of the season, add fuel stabilizer to the fuel tank. Be sure to keep the tank approximately 1/4 full of gasoline.
- Run for 2-3 minutes then turn off.
- Remove the spark plug, pour about 2 cc (about 4 drops) engine oil into the cylinder, slowly pull the starter handle of the recoil starter 2 or 3 times, and tighten the spark plug.
- Slowly pull the recoil starter handle until resistance is felt, and leave it in that position.
- Spray WD-40 or oil on the blades and screws to help reduce rust or corrosion.
- Clean the engine thoroughly with a clean cloth, put a cover on and store the engine indoors in well ventilated low humidity area.
- Store all auger styles with blade guard attached.
- At the beginning of the next season, drain gas tank of old fuel and add fresh winter blend gasoline.



LIMITED WARRANTY

The warrantor's obligation shall be limited to repairing or replacing any part, which upon examination by StrikeMaster, is determined to be defective. This obligation begins on the date of purchase (as evidenced by a product receipt) and continues for a period of ONE YEAR after purchase ("warranty period"), with the exception of engines and parts subject to wear and tear. Customer is responsible for shipping and transportation charges to the nearest warranty repair center.

Company warrants that Product, other than engines and parts subject to wear and tear, will perform substantially in accordance with the accompanying written materials [owner's manual] for a period of ONE YEAR. In the case of Honda engines, the warranty period duration is a period of 24 months for private residential use and 12 months for commercial/rental/institutional use. Parts subject to normal wear and tear are not covered by warranty including: air filter, fuel filter, any rubber part that comes in contact with fuel, clutch, spark plug, starter (recoil), and blades. In the event applicable law imposes any implied warranties, the implied warranty period is limited to ONE YEAR from the date reflected on the product receipt. Some jurisdictions do not allow such limitations on the duration of an implied warranty, so the above limitation may not apply.

TO THE MAXIMUM EXTENT PERMITTED BY APPLICABLE LAW, THE COMPANY AND AUTHORIZED SERVICE CENTERS DISCLAIM ALL OTHER WARRANTIES, EITHER EXPRESS OR IMPLIED, INCLUDING, BUT NOT LIMITED TO IMPLIED WARRANTIES OF MERCHANTABILITY AND FITNESS FOR A PARTICULAR PURPOSE WITH REGARD TO THE PRODUCT AND WRITTEN MATERIALS [OWNER'S MANUAL]. THIS LIMITED WARRANTY GIVES CUSTOMER SPECIFIC LEGAL RIGHTS. CUSTOMER MAY HAVE OTHER RIGHTS DEPENDING ON THE JURISDICTION.

TO THE MAXIMUM EXTENT PERMITTED BY APPLICABLE LAW, IN NO EVENT SHALL THE COMPANY OR AUTHORIZED SERVICE CENTER BE LIABLE FOR ANY DAMAGES WHATSOEVER (INCLUDING WITHOUT LIMITATION, SPECIAL, INCIDENTAL, OR CONSEQUENTIAL OR INDIRECT DAMAGES FOR PERSONAL INJURY, LOSS OF BUSINESS PROFITS, BUSINESS INTERRUPTION, LOSS OF BUSINESS INFORMATION OR ANY OTHER PECUNIARY LOSS) ARISING OUT OF THE USE OF OR INABILITY TO USE THIS PRODUCT, EVEN IF THE COMPANY HAS BEEN ADVISED OF THE POSSIBILITY OF SUCH DAMAGES. IN ANY CASE, THE COMPANY'S AND AUTHORIZED REPAIR CENTER'S ENTIRE LIABILITY UNDER ANY PROVISION OF THIS AGREEMENT SHALL BE LIMITED TO THE AMOUNT ACTUALLY PAID BY YOU FOR THE PRODUCT. BECAUSE SOME JURISDICTIONS DO NOT ALLOW THE EXCLUSION OR LIMITATION OF LIABILITY FOR CONSEQUENTIAL OR INCIDENTAL DAMAGES, THE ABOVE LIMITATION MAY NOT APPLY TO YOU.

Continued satisfying performance from your StrikeMaster power ice auger may be assured by applying a minimum amount of preventive maintenance.

WARRANTY SERVICE

Visit our website for up to date warranty service and non warranty repair service centers.

www.strikemaster.com